

Yastıklamalı Hidrolik Blok Silindirler Cushioned Block cylinders

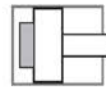
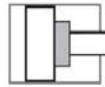
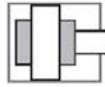

Yastıklamalı Blok Silindir

Nominal Basınç:	250 bar
Test Basıncı:	350 bar
Maksimum Strok:	200 mm
Piston Ø:	16 – 100 mm

Cushioned Block cylinder

Nominal pressure:	250 bar
Test pressure:	350 bar
Maximum stroke:	200 mm
Piston Ø:	16 to 100 mm

Yastıklamalı Hidrolik Blok Silindirler Cushioned Block cylinders

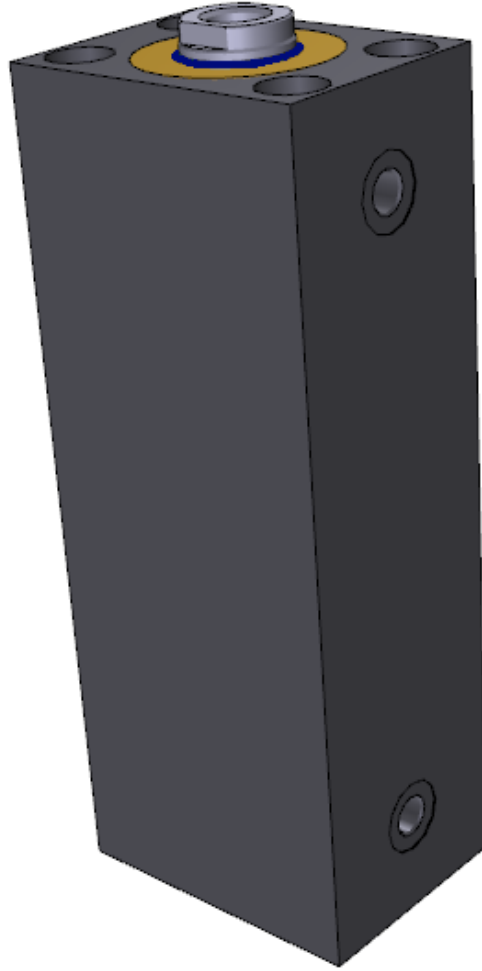

Yastıklamalı Blok Silindir

Nominal Basınç: 250 bar
Test Basıncı: 350 bar
Maksimum Strok: 200 mm
Piston Ø: 16 – 100 mm

Cushioned Block cylinder

Nominal pressure: 250 bar
Test pressure: 350 bar
Maximum stroke: 200 mm
Piston Ø: 16 to 100 mm

Yastıklamalı Hidrolik Blok Silindirler

Cushioned Block cylinders

Genel açıklamalar

General description

- **Blok silindirler** kısa stroklu çalışma alanları için tasarlanmış, çok küçük montaj boyutlarına sahip kompakt silindirlerdir. Bu silindirler sert gövde yapıları ve krom kaplı milleriyle aşağıda listelenen çalışma koşulları ile üretilmektedir.
- **Piston:**
Ø16 - Ø100 mm piston çap aralığında DIN 3320 normuna göre imal edilir.
- **Çalışma basıncı:**
Nominal basınç maksimum 250 bar. Yüksek çalışma basınçları için lütfen bize ulaşın.
- **Çalışma sıvıları:**
Hidrolik yağ, H, HL, HLP DIN 51524/51525 normlarında. Yangın sıvıları ya da su gibi diğer işletim sıvıları istek üzerine kullanılabilir.
- **Çalışma sıcaklığı:**
Silindirler varsayılan olarak +10°C ile +80°C sıcaklık aralığında çalışacak sızdırmazlık elemanları ile donatılmıştır. Yüksek sıcaklığa dayanıklı sızdırmazlık elemanları, tasarım değişiklikleri olmadan monte edilebilir. (+180°C)
- **Piston hızı:**
0.5 m/s maksimum. Yüksek piston hızları için irtibata geçiniz.
- **Strok:**
Standart stroklar dökümantasyonda listelenmiştir. Ayrıca kullanıcılar tarafından kısa istenebilir. Blok silindirlerde uzun hareketler de talep edilebilir.
- **Toleranslar:**
Hareket miktarına bağlı toleranslar DIN ISO 2768 –g T1 normunda imal edilir. Diğer toleranslar DIN ISO 2768- m T1 normundadır.

- **Block cylinders** are very compact cylinders with smallest installation dimensions for short stroke operation. By default these cylinders are fabricated with ground and chrome plated rods for the operating conditions given below.
- **Piston:**
Piston Ø16 to Ø100 mm according to DIN 3320.
- **Operating pressure:**
Nominal pressure maximum 250 bar, for higher operating pressures please contact us.
- **Operating fluids:**
Hydraulic oil on the basis of mineral oils for example H, HL, HLP-oils in DIN 51524/51525 norm. Other operating fluids like fire fluids or water may be used upon request.
- **Operating temperature:**
By default the cylinder is fitted with seals for a temperature range from +10°C to +80°C. High temperature resistant seals can be fitted without changes in design. (+180°C)
- **Piston travel speed:**
Maximum of 0.5m/s. Please contact for higher piston travel speeds.
- **Stroke:**
Standart strokes listed in the data sheets can be reduced user-defined. Block cylinders are also available with longer stroke.
- **Tolerances:**
Stroke tolerances and stroke dependent dimensions according to DIN ISO 2768 – g T1. Other tolerances according to DIN ISO 2768 – m T1.

Yastıklamalı Hidrolik Blok Silindirler

Cushioned Block cylinders

Blok Silindir Yastıklaması

Cushioning of the stroke

• Silindirde hareket sonuna hızlı yaklaşma ile aynı zamanda çok dinamik tahrikler için dahili ve harici yastıklama tavsiye edilir.

• Internal and external cushioning is advisable for high travel speeds with fast approach to the end position i.e. for also very dynamic drives.

• Hidrolik blok silindirlerde yastıklama, piston kafasının kapaklara ulaşmadan önce hızının yavaşlatılması ile yapılır. Piston kafasını strok sonuna yakın yavaşlatmak, pistonun hidrolik silindir kapaklarına çarpmasını durdurarak mekanik şoku önler. Sağlayacağı diğer avantajlar ise; çalışma anındaki oluşan gürültünün azaltılması ve titreşimin giderilmesidir.

• Hydraulic block cylinder cushioning slows the speed of a cylinder piston before it reaches the end caps. Decelerating the cylinder rod near end-of-stroke stops the piston from striking the hydraulic cylinder ends, preventing mechanical shock. Additional benefits include: Reduced noise and vibration.

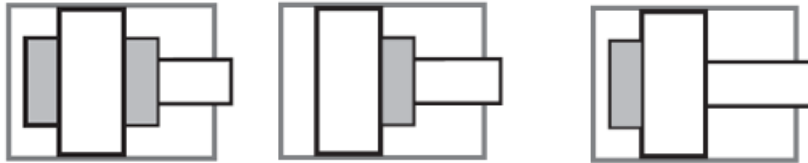

Teknik data

Technical data

	25	32	40	50	63	80	100
Piston Ø – mm Piston Ø	25	32	40	50	63	80	100
Mil Ø mm Piston-rod Ø	16	20	25	32	40	50	60
Piston baskı alanı (A _K) cm ² Piston face (pushing)	4.91	8.04	12.56	19.63	31.16	50.24	78.50
Piston çekme alanı (A _R) cm ² Piston ring face (drawing action)	2.90	4.90	7.65	11.59	18.60	30.61	50.24
Kuvvet (baskı) (A _K) kgf 100 bar Force (pushing) 250 bar	491 1227.5	804 2010	1256 3140	1963 4907.5	3116 7790	5024 12560	7850 19625
Kuvvet (çekme) (A _R) kgf 100 bar Force (drawing action) 250 bar	290 725	490 1225	765 1912.5	1159 2897.5	1860 4650	3061 7652.5	5024 12560

Standart stroklar

Standart strokes

	25	32	40	50	63	80	100
Piston Ø – mm Piston Ø	25	32	40	50	63	80	100
Strok – mm Stroke							
30							
32							
40							•
50	•	•	•	•			
60	•				•		
80						•	
100		•	•	•	•		•
130						•	•

Gövde yapıları

Construction forms

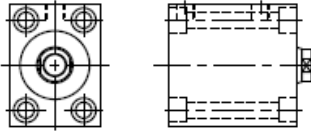
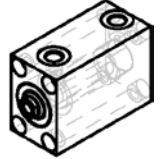
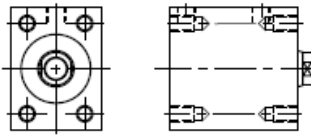
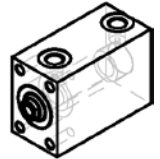
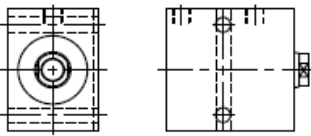
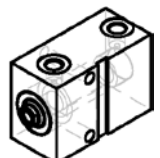
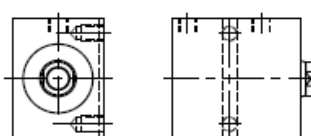
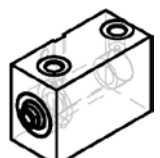
Kod Code		Açıklama Description	
01		<p>Eksene paralel montaj Mil tarafından veya karşısından, boydan boya açılmış 4 delikten bağlanır. (Civatalar DIN 912 Normunda) Hidrolik bağlantı delikleri BSPT.</p> <p>Axial attachment 4 longitudinal holes on rod and bottom side with head bolts according to DIN 912. Port threads are BSPT.</p>	
02		<p>Eksene paralel montaj Mil tarafından veya karşısından açılmış 4 adet diş ile bağlanır. Hidrolik bağlantı delikleri BSPT.</p> <p>Axial attachment With 4 threaded blind holes on rod and bottom side. Port threads are BSPT.</p>	
03		<p>Radyal montaj Boydan boya açılmış 2 delik ve kama ile bağlanır. Hidrolik bağlantı delikleri BSPT.</p> <p>Radial attachment Adjusted with through holes and groove. Port threads are BSPT.</p>	
04		<p>Radyal montaj Kama kanalı tarafından açılmış 2 adet diş ve kama ile bağlanır. Hidrolik bağlantı delikleri BSPT.</p> <p>Radial attachment Adjusted with 2 threaded blind holes by groove side. Port threads are BSPT.</p>	

Gövde yapıları

Construction forms

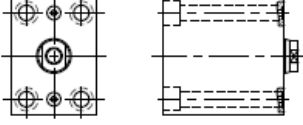
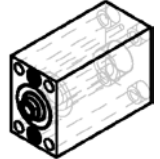
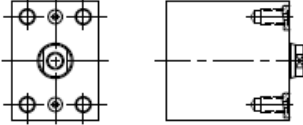
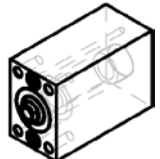
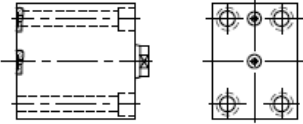
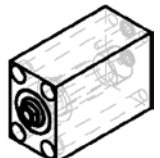
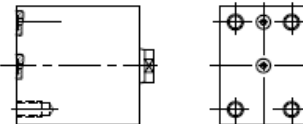
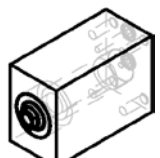
Kod Code		Açıklama Description	
12		<p>Eksene paralel montaj Mil tarafından, boydan boya açılmış 4 delikten bağlanır. (Civatalar DIN 912 Normunda) Hidrolik bağlantı delikleri mil tarafında, O-Ring'li. Axial attachment 4 longitudinal holes on rod side with head bolts according to DIN 912. O-Ring seals on rod side.</p>	
14		<p>Eksene paralel montaj Mil tarafından açılmış 4 adet diş ile bağlanır. Hidrolik bağlantı delikleri mil tarafında, O-Ring'li. Axial attachment With 4 threaded blind holes on rod side. O-Ring seals on rod side.</p>	
21		<p>Eksene paralel montaj Mil tarafından, boydan boya açılmış 4 delikten bağlanır. (Civatalar DIN 912 Normunda) Hidrolik bağlantı delikleri tabanda, O-Ring'li. Axial attachment 4 longitudinal holes on rod side with head bolts according to DIN 912. O-Ring seals on bottom side.</p>	
25		<p>Eksene paralel montaj Tabandan açılmış 4 adet diş ile bağlanır. Hidrolik bağlantı delikleri tabanda, O-Ring'li. Axial attachment With 4 threaded blind holes on bottom side. O-Ring seals on bottom side.</p>	

Gövde yapıları

Construction forms

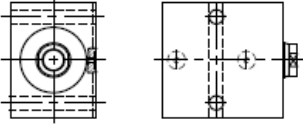
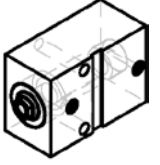
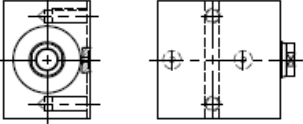
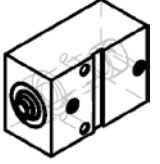
Kod Code		Açıklama Description	
33		<p>Radyal montaj Boydan boya açılmış 2 delik ve kama ile bağlanır. Hidrolik bağlantı delikleri kama kanalı tarafında, O-Ring'li.</p> <p>Radial attachment Adjusted with 2 through holes and groove. O-Ring seals on groove side.</p>	
34		<p>Radyal montaj Kama kanalı tarafından açılmış 2 adet diş ve kama ile bağlanır. Hidrolik bağlantı delikleri kama kanalı tarafında, O-Ring'li.</p> <p>Radial attachment Adjusted with 2 threaded blind holes by groove side. O-Ring seals on groove side</p>	

Opsiyonlar

Options

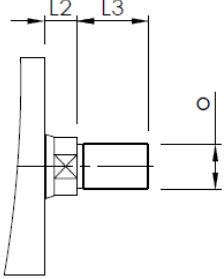
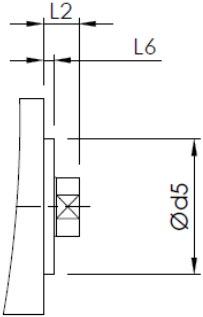
Açıklama	Kod Code	Description
<p>FKM (Viton®) Sızdırmazlık</p> <p>Blok Silindirimiz, standart olarak 80°C'ye kadar olan ortamlar için uygundur. 180°C'ye kadar olan ortamlar için FKM (Viton®) sızdırmazlık elemanları tercih edilmelidir.</p>	V	<p>FKM (Viton®) seals</p> <p>Our block cylinders are suitable for environments up to 80°C as standard. For media up to 180°C FKM (Viton®) seals should be preferred.</p>
	D	<p>Dıştan dişli mil ucu.</p> <p>Piston-rod end with external thread.</p>
	Z	<p>Merkezleme faturası</p> <p>With centering collar</p>



Ölçüler

Dimensions

Piston Ø – mm / Piston Ø	25	32	40	50	63	80	100
d5_{f7}	32	38	46	57	72	94	116
L2	7	10	10	10	14	14	15
L3	15	15	25	30	40	40	60
L6	2	2	2	2	2	2	2
o	M10	M12	M16	M20	M27	M30	M42

Yastıklama

Cushioning

204	206	208
		
<p>Çift etkili - İki taraf yastıklamalı</p> <p>Double acting – Forward and return stroke cushioned. (both ends)</p>	<p>Çift etkili - Mil tarafı yastıklamalı</p> <p>Double acting – Cushioned forward stroke</p>	<p>Çift etkili - Piston tarafı yastıklamalı</p> <p>Double acting – Cushioned return stroke</p>

Minimum Strok

Minimum Stroke

Piston Ø – mm / Piston Ø	25	32	40	50	63	80	100
Minimum Strok - mm Minimum Stroke	10	7	5	5	7	7	7

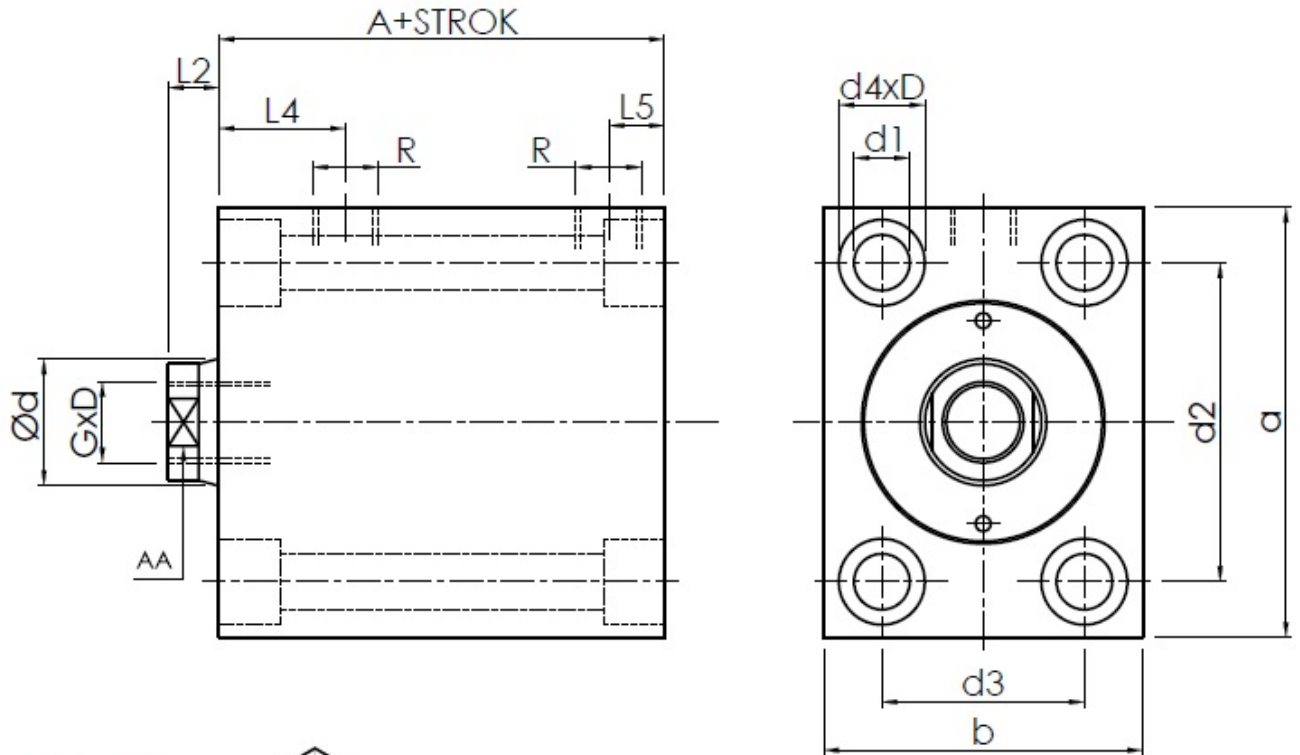

01

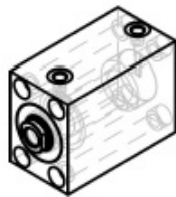

Yastıklama

Cushioning

204

206

208



Ölçüler BSD250 01

Dimensions

Piston Ø – mm / Piston Ø	25	32	40	50	63	80	100
Mil Ød / rod Ø	16	20	25	32	40	50	60
A 204 BS250 ≤100	95	97	105	119	140	156	163
BSU250 >100-200	108	112	125	133	157	174	180
A 206 BS250 ≤100	63	72	78	89	102	114	121
BSU250 >100-200	89	100	113	121	142	160	164
A 208 BS250 ≤100	76	75	81	95	110	127	132
BSU250 >100-200	89	90	101	109	127	145	149
a	65	75	85	100	125	160	200
b	45	55	63	75	95	120	150
d1	8.5	10.5	10.5	13	17	21	25
d2	50	55	63	76	95	120	158
d3	30	35	40	45	65	80	108
L2	7	10	10	10	14	14	15
L4 204 BS250 ≤100	21	26	28	32	35	43	45
BSU250 >100-200	21	26	28	32	35	43	45
L4 206 BS250 ≤100	21	26	28	32	35	43	45
BSU250 >100-200	21	26	28	32	35	43	45
L4 208 BS250 ≤100	20	23	25	27	28	36	39
BSU250 >100-200	20	24	25	27	28	36	39
L5 204 BS250 ≤100	21	26	28	32	35	43	45
BSU250 >100-200	21	26	28	32	35	43	45
L5 206 BS250 ≤100	11	11	11	12	17	20	18
BSU250 >100-200	20	24	25	27	28	36	39
L5 208 BS250 ≤100	21	26	28	32	35	43	45
BSU250 >100-200	21	26	28	32	35	43	45
R	G1/4"	G1/4"	G1/4"	G1/4"	G3/8"	G1/2"	G1/2"
AA	13	17	21	26	32	41	---
GxD	M10x15	M12x15	M16x25	M20x30	M27x40	M30x40	M42x60
d4xD	14x9	17x11	17x11	19x13	25x17	31x21	37x25

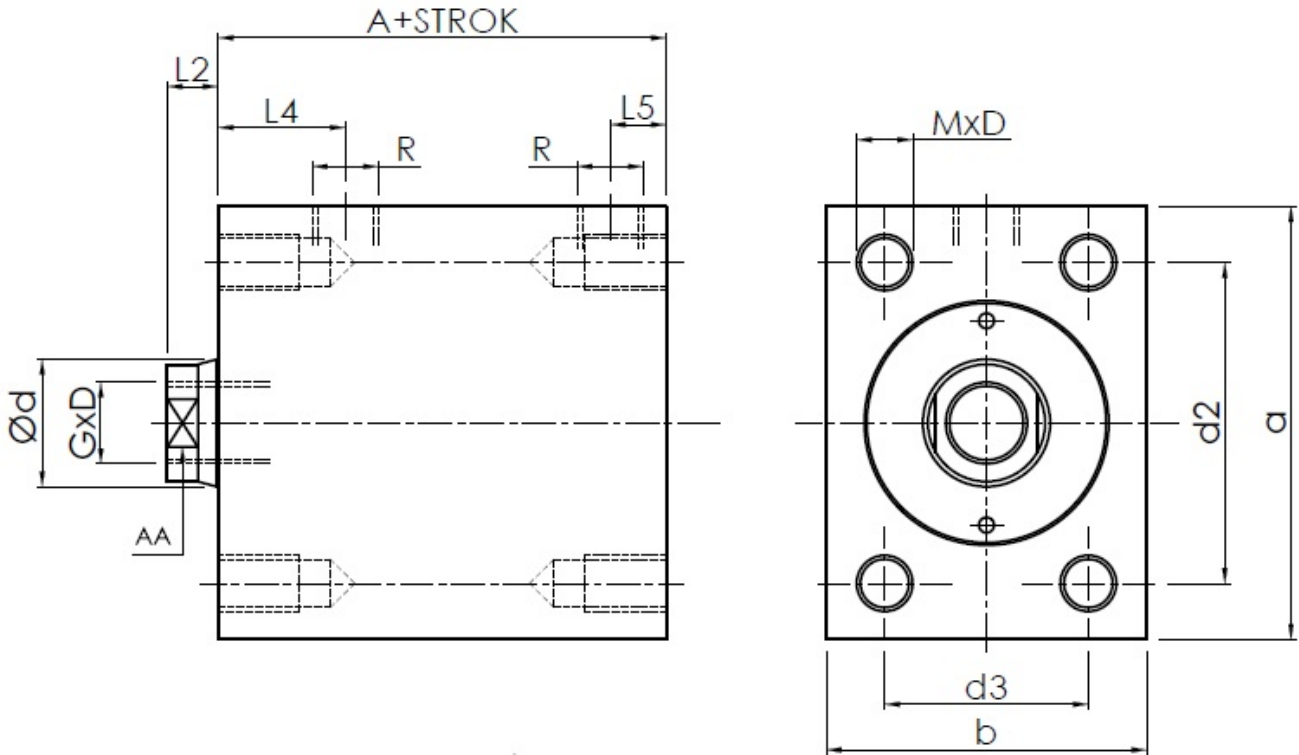

02

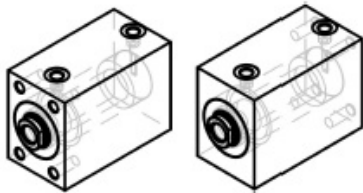

Yastıklama

Cushioning

204

206

208



Ölçüler BSD250 02

Dimensions

Piston Ø – mm / Piston Ø	25	32	40	50	63	80	100
Mil Ød / rod Ø	16	20	25	32	40	50	60
A 204 BS250 ≤100	95	97	105	119	140	156	163
BSU250 >100-200	108	112	125	133	157	174	180
A 206 BS250 ≤100	63	72	78	89	102	114	121
BSU250 >100-200	89	100	113	121	142	160	164
A 208 BS250 ≤100	76	75	81	95	110	127	132
BSU250 >100-200	89	90	101	109	127	145	149
a	65	75	85	100	125	160	200
b	45	55	63	75	95	120	150
d2	50	55	63	76	95	120	158
d3	30	35	40	45	65	80	108
L2	7	10	10	10	14	14	15
L4 204 BS250 ≤100	21	26	28	32	35	43	45
BSU250 >100-200	21	26	28	32	35	43	45
L4 206 BS250 ≤100	21	26	28	32	35	43	45
BSU250 >100-200	21	26	28	32	35	43	45
L4 208 BS250 ≤100	20	23	25	27	28	36	39
BSU250 >100-200	20	24	25	27	28	36	39
L5 204 BS250 ≤100	21	26	28	32	35	43	45
BSU250 >100-200	21	26	28	32	35	43	45
L5 206 BS250 ≤100	11	11	11	12	17	20	18
BSU250 >100-200	20	24	25	27	28	36	39
L5 208 BS250 ≤100	21	26	28	32	35	43	45
BSU250 >100-200	21	26	28	32	35	43	45
R	G1/4"	G1/4"	G1/4"	G1/4"	G3/8"	G1/2"	G1/2"
AA	13	17	21	26	32	41	---
GxD	M10x15	M12x15	M16x25	M20x30	M27x40	M30x40	M42x60
MxD	M8x16	M10x20	M10x20	M12x24	M16x32	M20x35	M24x50

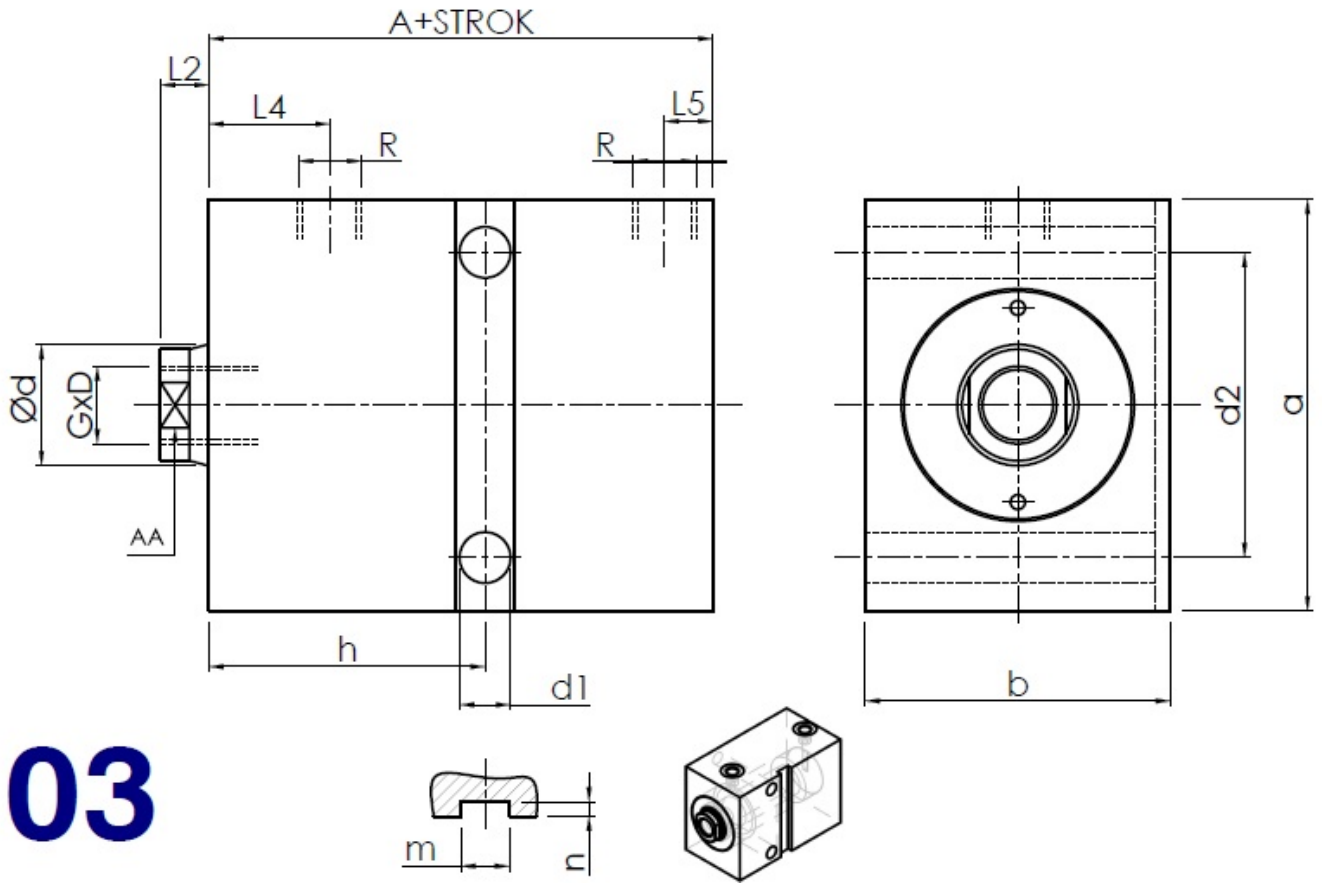

Yastıklama

Cushioning

204

206

208



Ölçüler BSD250 03

Dimensions

Piston Ø – mm / Piston Ø	25	32	40	50	63	80	100
Mil Ød / rod Ø	16	20	25	32	40	50	60
A 204 BS250 ≤100	95	97	105	119	140	156	163
BSU250 >100-200	108	112	125	133	157	174	180
A 206 BS250 ≤100	63	72	78	89	102	114	121
BSU250 >100-200	89	100	113	121	142	160	164
A 208 BS250 ≤100	76	75	81	95	110	127	132
BSU250 >100-200	89	90	101	109	127	145	149
a	65	75	85	100	125	160	200
b	45	55	63	75	95	120	150
d1	8.5	10.5	10.5	13	17	21	25
d2	50	55	63	76	95	120	158
h	33	38	40	44	50	60	64
L2	7	10	10	10	14	14	15
L4 204 BS250 ≤100	21	26	28	32	35	43	45
BSU250 >100-200	21	26	28	32	35	43	45
L4 206 BS250 ≤100	21	26	28	32	35	43	45
BSU250 >100-200	21	26	28	32	35	43	45
L4 208 BS250 ≤100	20	23	25	27	28	36	39
BSU250 >100-200	20	24	25	27	28	36	39
L5 204 BS250 ≤100	21	26	28	32	35	43	45
BSU250 >100-200	21	26	28	32	35	43	45
L5 206 BS250 ≤100	11	11	11	12	17	20	18
BSU250 >100-200	20	24	25	27	28	36	39
L5 208 BS250 ≤100	21	26	28	32	35	43	45
BSU250 >100-200	21	26	28	32	35	43	45
m	10	12	12	15	20	24	28
n	2	3	3	5	5	7	7
R	G1/4"	G1/4"	G1/4"	G1/4"	G3/8"	G1/2"	G1/2"
AA	13	17	21	26	32	41	---
GxD	M10x15	M12x15	M16x25	M20x30	M27x40	M30x40	M42x60

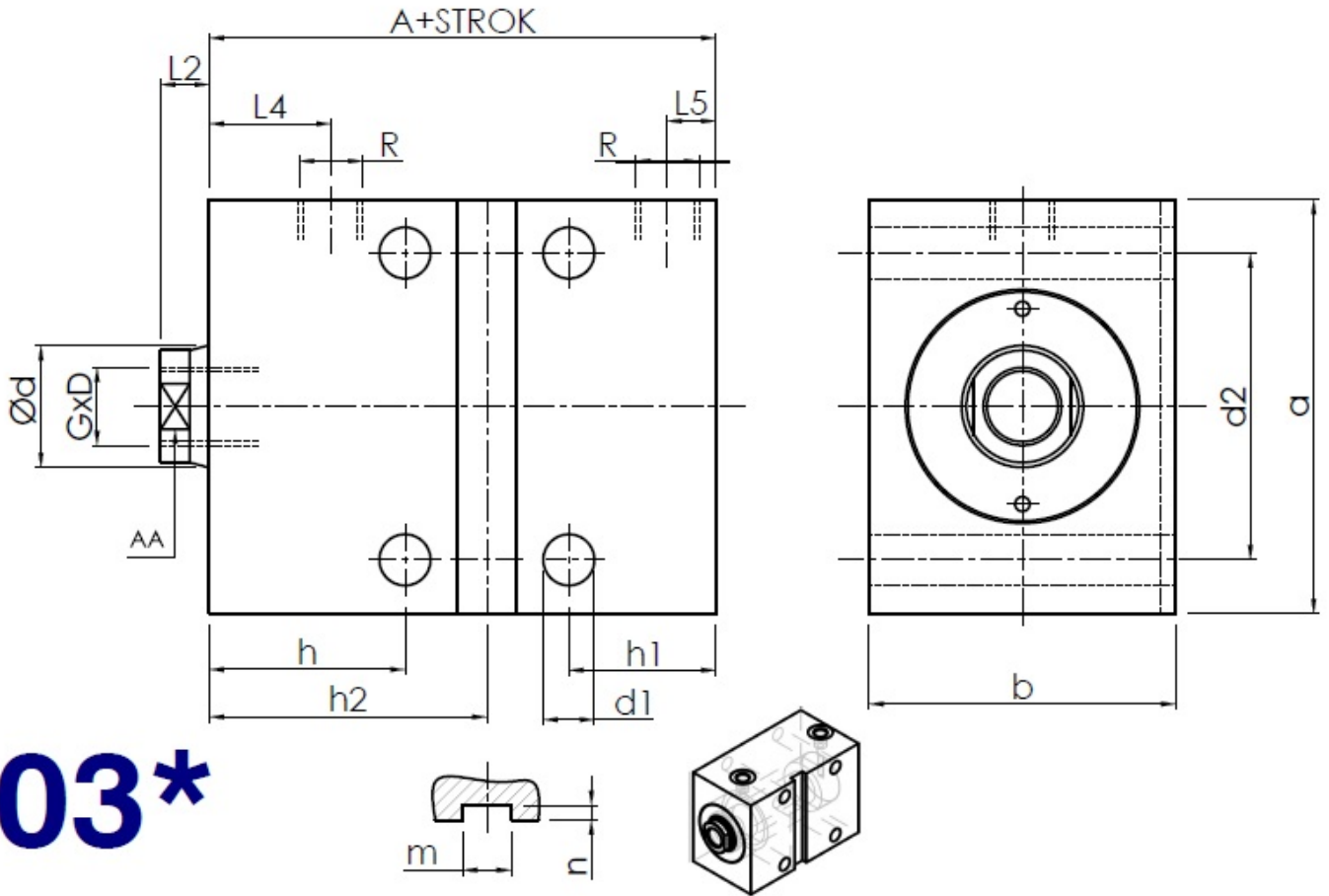

* $\varnothing 16-63$ strok = 100 mm $\varnothing 80-100$ strok ≥ 100 mm

Yastıklama

Cushioning

204

206

208



Ölçüler BSD250 03*

Dimensions

Piston Ø – mm / Piston Ø		25	32	40	50	63	80	100
Mil Ød / rod Ø		16	20	25	32	40	50	60
A 204	BS250 ≤100	95	97	105	119	140	156	163
	BSU250 >100-200	108	112	125	133	157	174	180
A 206	BS250 ≤100	63	72	78	89	102	114	121
	BSU250 >100-200	89	100	113	121	142	160	164
A 208	BS250 ≤100	76	75	81	95	110	127	132
	BSU250 >100-200	89	90	101	109	127	145	149
a		65	75	85	100	125	160	200
b		45	55	63	75	95	120	150
d1		8.5	10.5	10.5	13	17	21	25
d2		50	55	63	76	95	120	158
h		33	38	40	44	50	60	64
h1		26	27	27	30	41	47	54
h2		Standart üretimde h2=h. Farklı ölçü talep edilebilir. Standart production h2=h. Different size can be requested.						
L2		7	10	10	10	14	14	15
L4 204	BS250 ≤100	21	26	28	32	35	43	45
	BSU250 >100-200	21	26	28	32	35	43	45
L4 206	BS250 ≤100	21	26	28	32	35	43	45
	BSU250 >100-200	21	26	28	32	35	43	45
L4 208	BS250 ≤100	20	23	25	27	28	36	39
	BSU250 >100-200	20	24	25	27	28	36	39
L5 204	BS250 ≤100	21	26	28	32	35	43	45
	BSU250 >100-200	21	26	28	32	35	43	45
L5 206	BS250 ≤100	11	11	11	12	17	20	18
	BSU250 >100-200	20	24	25	27	28	36	39
L5 208	BS250 ≤100	21	26	28	32	35	43	45
	BSU250 >100-200	21	26	28	32	35	43	45
m		10	12	12	15	20	24	28
n		2	3	3	5	5	7	7
R		G1/4"	G1/4"	G1/4"	G1/4"	G3/8"	G1/2"	G1/2"
AA		13	17	21	26	32	41	---
GxD		M10x15	M12x	M16x25	M20x30	M27x40	M30x40	M42x60

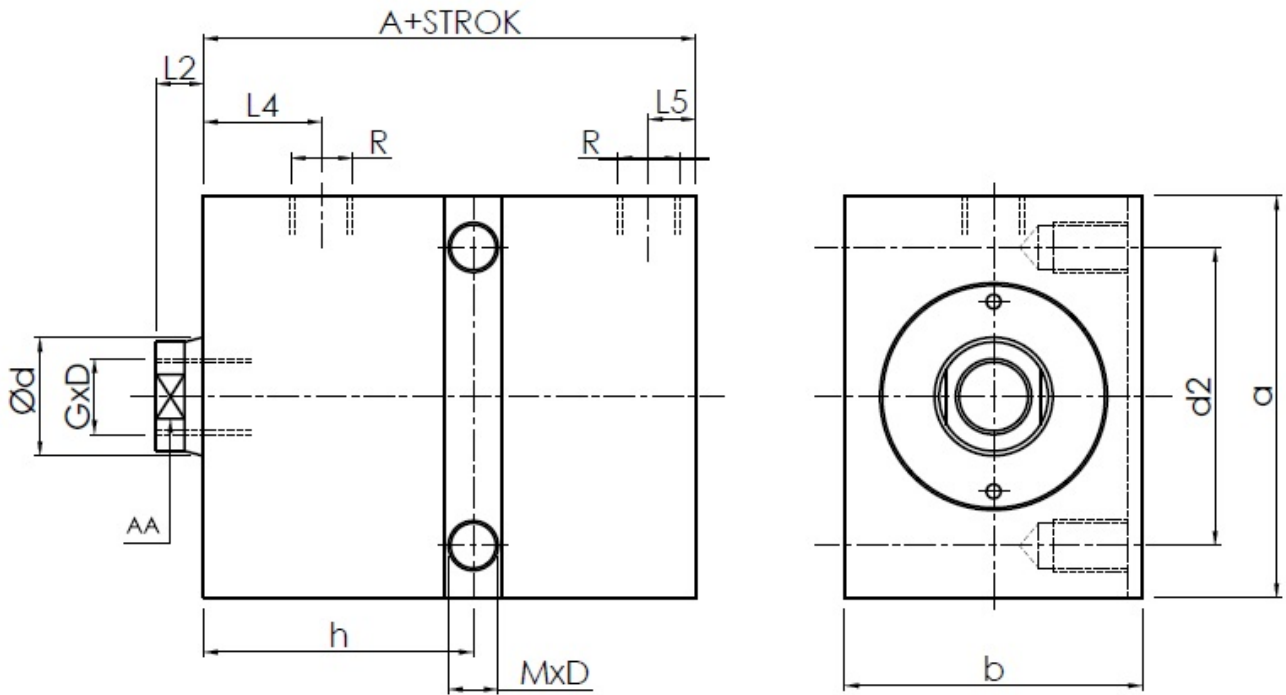

04

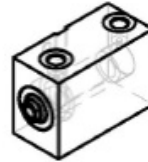
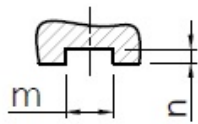

Yastıklama

Cushioning

204

206

208



Piston Ø – mm / Piston Ø	25	32	40	50	63	80	100
Mil Ød / rod Ø	16	20	25	32	40	50	60
A 204 BS250 ≤100	95	97	105	119	140	156	163
BSU250 >100-200	108	112	125	133	157	174	180
A 206 BS250 ≤100	63	72	78	89	102	114	121
BSU250 >100-200	89	100	113	121	142	160	164
A 208 BS250 ≤100	76	75	81	95	110	127	132
BSU250 >100-200	89	90	101	109	127	145	149
a	65	75	85	100	125	160	200
b	45	55	63	75	95	120	150
d2	50	55	63	76	95	120	158
h	33	38	40	44	50	60	64
L2	7	10	10	10	14	14	15
L4 204 BS250 ≤100	21	26	28	32	35	43	45
BSU250 >100-200	21	26	28	32	35	43	45
L4 206 BS250 ≤100	21	26	28	32	35	43	45
BSU250 >100-200	21	26	28	32	35	43	45
L4 208 BS250 ≤100	20	23	25	27	28	36	39
BSU250 >100-200	20	24	25	27	28	36	39
L5 204 BS250 ≤100	21	26	28	32	35	43	45
BSU250 >100-200	21	26	28	32	35	43	45
L5 206 BS250 ≤100	11	11	11	12	17	20	18
BSU250 >100-200	20	24	25	27	28	36	39
L5 208 BS250 ≤100	21	26	28	32	35	43	45
BSU250 >100-200	21	26	28	32	35	43	45
m	10	12	12	15	20	24	28
n	2	3	3	5	5	7	7
R	G1/4"	G1/4"	G1/4"	G1/4"	G3/8"	G1/2"	G1/2"
AA	13	17	21	26	32	41	---
GxD	M10x15	M12x15	M16x25	M20x30	M27x40	M30x40	M42x60
MxD	M8x16	M10x20	M10x20	M12x24	M16x32	M20x35	M24x50

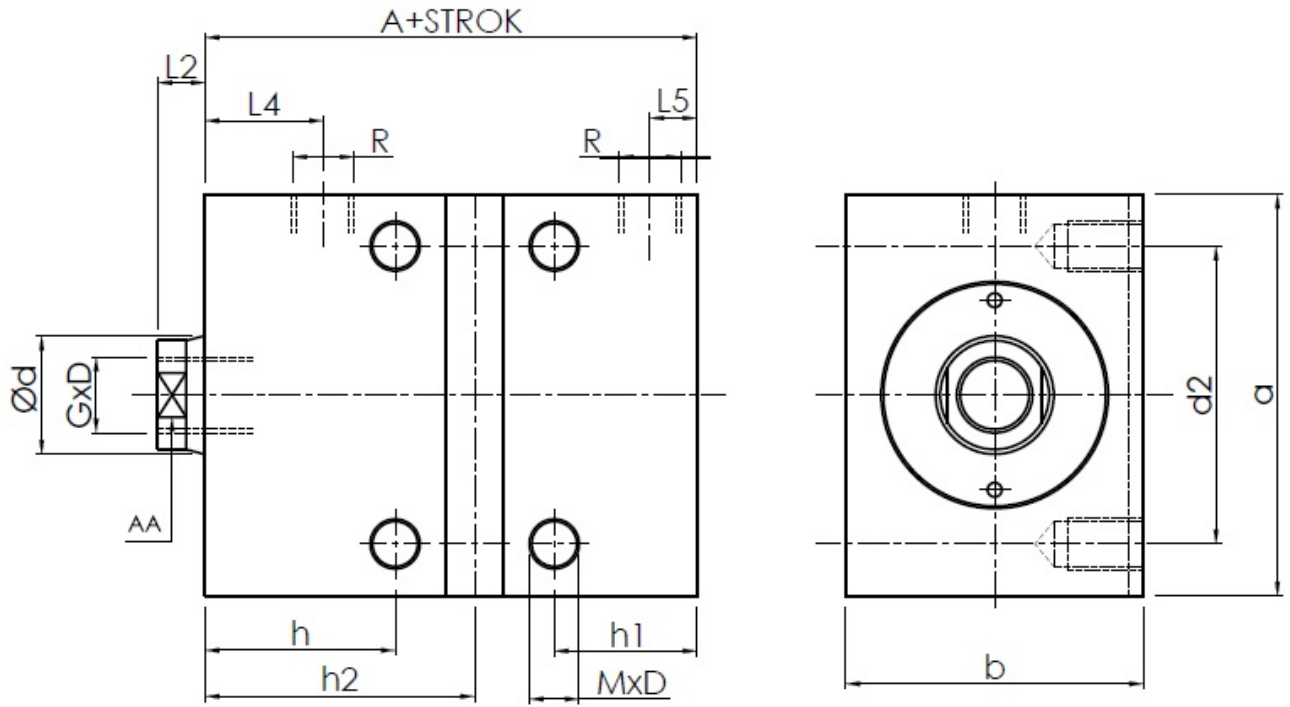

04*

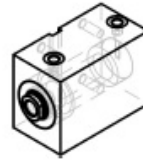
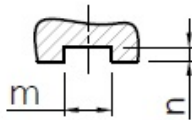

* $\varnothing 16-63$ strok = 100 mm $\varnothing 80-100$ strok ≥ 100 mm

Yastıklama

Cushioning

204

206

208



Ölçüler BSD250 04*

Dimensions

Piston Ø – mm / Piston Ø	25	32	40	50	63	80	100
Mil Ød / rod Ø	16	20	25	32	40	50	60
A 204 BS250 ≤100	95	97	105	119	140	156	163
BSU250 >100-200	108	112	125	133	157	174	180
A 206 BS250 ≤100	63	72	78	89	102	114	121
BSU250 >100-200	89	100	113	121	142	160	164
A 208 BS250 ≤100	76	75	81	95	110	127	132
BSU250 >100-200	89	90	101	109	127	145	149
a	65	75	85	100	125	160	200
b	45	55	63	75	95	120	150
d2	50	55	63	76	95	120	158
h	33	38	40	44	50	60	64
h1	26	27	27	30	41	47	54
h2	Standart üretimde h2=h. Farklı ölçü talep edilebilir. Standart production h2=h. Different size can be requested.						
L2	7	10	10	10	14	14	15
L4 204 BS250 ≤100	21	26	28	32	35	43	45
BSU250 >100-200	21	26	28	32	35	43	45
L4 206 BS250 ≤100	21	26	28	32	35	43	45
BSU250 >100-200	21	26	28	32	35	43	45
L4 208 BS250 ≤100	20	23	25	27	28	36	39
BSU250 >100-200	20	24	25	27	28	36	39
L5 204 BS250 ≤100	21	26	28	32	35	43	45
BSU250 >100-200	21	26	28	32	35	43	45
L5 206 BS250 ≤100	11	11	11	12	17	20	18
BSU250 >100-200	20	24	25	27	28	36	39
L5 208 BS250 ≤100	21	26	28	32	35	43	45
BSU250 >100-200	21	26	28	32	35	43	45
m	10	12	12	15	20	24	28
n	2	3	3	5	5	7	7
R	G1/4"	G1/4"	G1/4"	G1/4"	G3/8"	G1/2"	G1/2"
AA	13	17	21	26	32	41	---
GxD	M10x15	M12x15	M16x25	M20x30	M27x40	M30x40	M42x60
MxD	M8x16	M10x20	M10x20	M12x24	M16x32	M20x35	M24x50

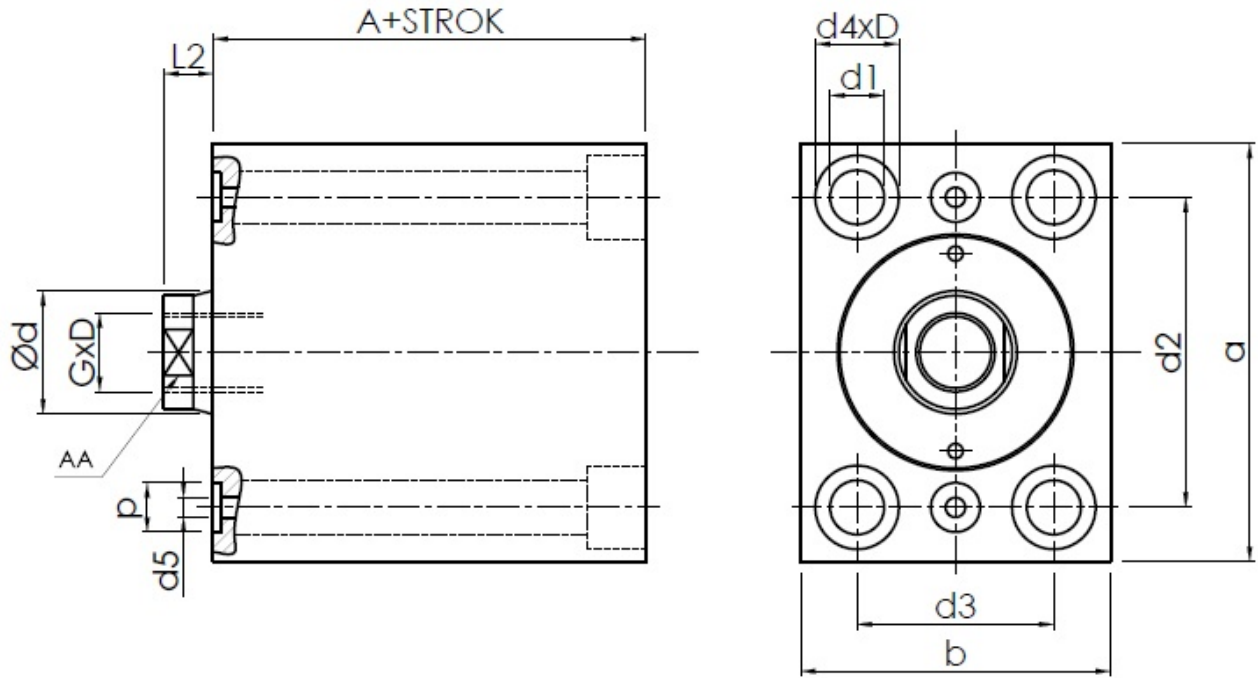

12

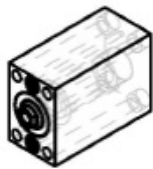

Yastıklama

Cushioning

204

206

208



Ölçüler BSD250 12

Dimensions

Piston Ø – mm / Piston Ø	25	32	40	50	63	80	100
Mil Ød / rod Ø	16	20	25	32	40	50	60
A 204 BS250 ≤100	95	97	105	119	140	156	163
BSU250 >100-200	108	112	125	133	157	174	180
A 206 BS250 ≤100	63	72	78	89	102	114	121
BSU250 >100-200	89	100	113	121	142	160	164
A 208 BS250 ≤100	76	75	81	95	110	127	132
BSU250 >100-200	89	90	101	109	127	145	149
a	65	75	85	100	125	160	200
b	45	55	63	75	95	120	150
d1	8.5	10.5	10.5	13	17	21	25
d2	50	55	63	76	95	120	158
d3	30	35	40	45	65	80	108
d5	4	4	4	5	6	6	8
L2	7	10	10	10	14	14	15
p	9	9	9	10	10	13	15
AA	13	17	21	26	32	41	---
GxD	M10x15	M12x15	M16x25	M20x30	M27x40	M30x40	M42x60
d4xD	14x9	17x11	17x11	19x13	25x17	31x21	37x25

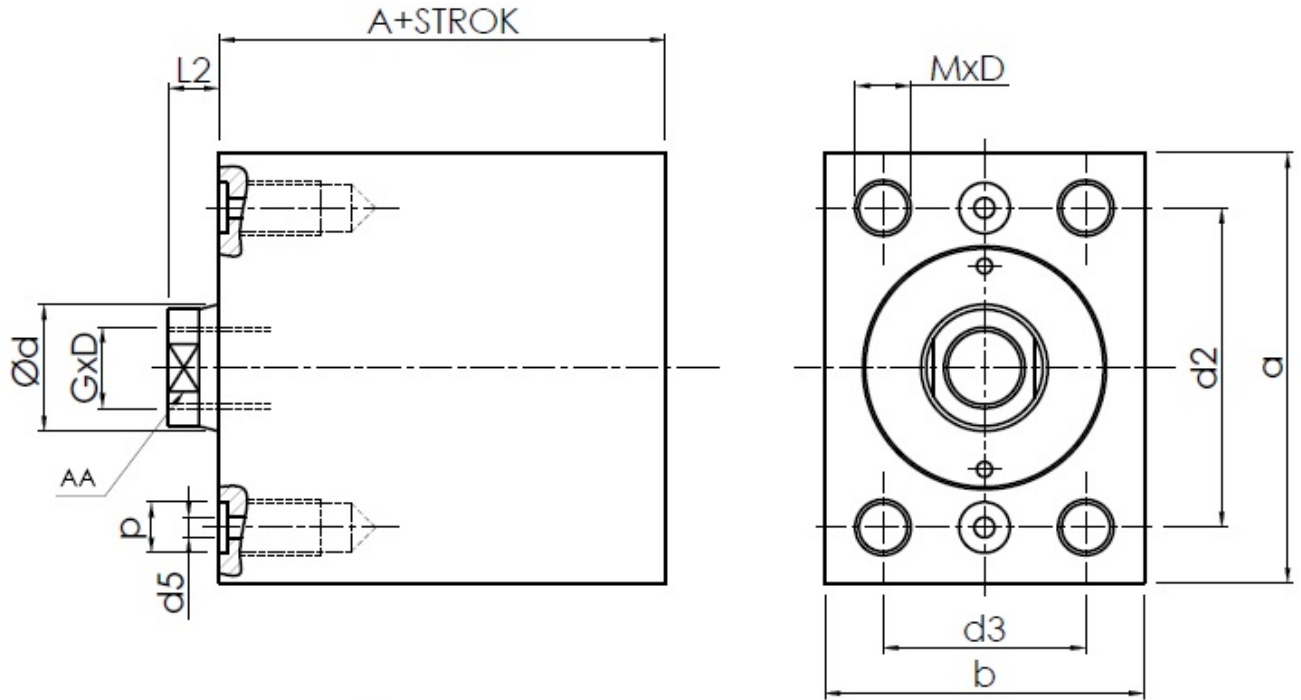

14

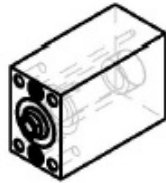

Yastıklama

Cushioning

204

206

208



Ölçüler BSD250 14

Dimensions

Piston Ø – mm / Piston Ø	25	32	40	50	63	80	100
Mil Ød / rod Ø	16	20	25	32	40	50	60
A 204 BS250 ≤100	95	97	105	119	140	156	163
BSU250 >100-200	108	112	125	133	157	174	180
A 206 BS250 ≤100	63	72	78	89	102	114	121
BSU250 >100-200	89	100	113	121	142	160	164
A 208 BS250 ≤100	76	75	81	95	110	127	132
BSU250 >100-200	89	90	101	109	127	145	149
a	65	75	85	100	125	160	200
b	45	55	63	75	95	120	150
d2	50	55	63	76	95	120	158
d3	30	35	40	45	65	80	108
d5	4	4	4	5	6	6	8
L2	7	10	10	10	14	14	15
p	9	9	9	10	10	13	15
AA	13	17	21	26	32	41	---
GxD	M10x15	M12x15	M16x25	M20x30	M27x40	M30x40	M42x60
MxD	M8x12	M10x20	M10x20	M12x24	M16x32	M20x35	M24x50

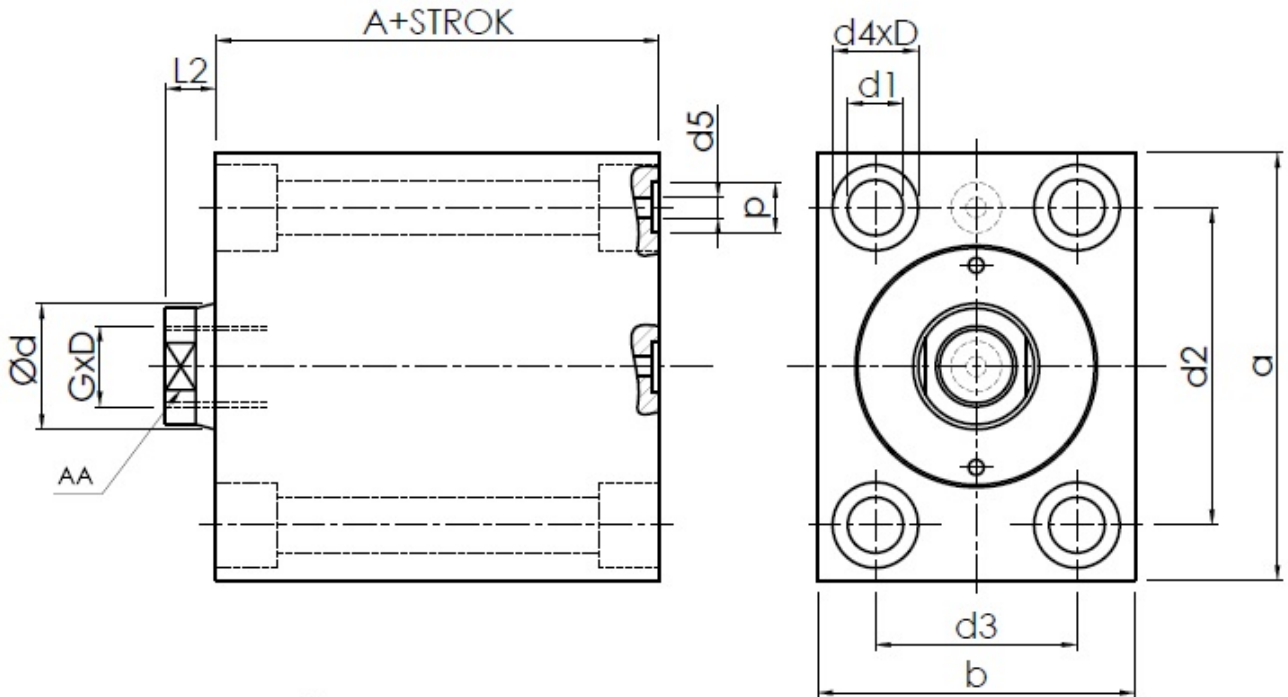

21

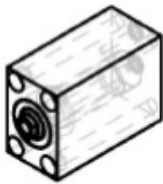

Yastıklama

Cushioning

204

206

208



Ölçüler BSD250 21

Dimensions

Piston Ø – mm / Piston Ø	25	32	40	50	63	80	100
Mil Ød / rod Ø	16	20	25	32	40	50	60
A 204 BS250 ≤100	95	97	105	119	140	156	163
BSU250 >100-200	108	112	125	133	157	174	180
A 206 BS250 ≤100	63	72	78	89	102	114	121
BSU250 >100-200	89	100	113	121	142	160	164
A 208 BS250 ≤100	76	75	81	95	110	127	132
BSU250 >100-200	89	90	101	109	127	145	149
a	65	75	85	100	125	160	200
b	45	55	63	75	95	120	150
d1	8.5	10.5	10.5	13	17	21	25
d2	50	55	63	76	95	120	158
d3	30	35	40	45	65	80	108
d5	4	4	4	5	6	6	8
L2	7	10	10	10	14	14	15
p	9	9	9	10	10	13	15
AA	13	17	21	26	32	41	---
GxD	M10x15	M12x15	M16x25	M20x30	M27x40	M30x40	M42x60
d4xD	14x9	17x11	17x11	19x13	25x17	31x21	37x25

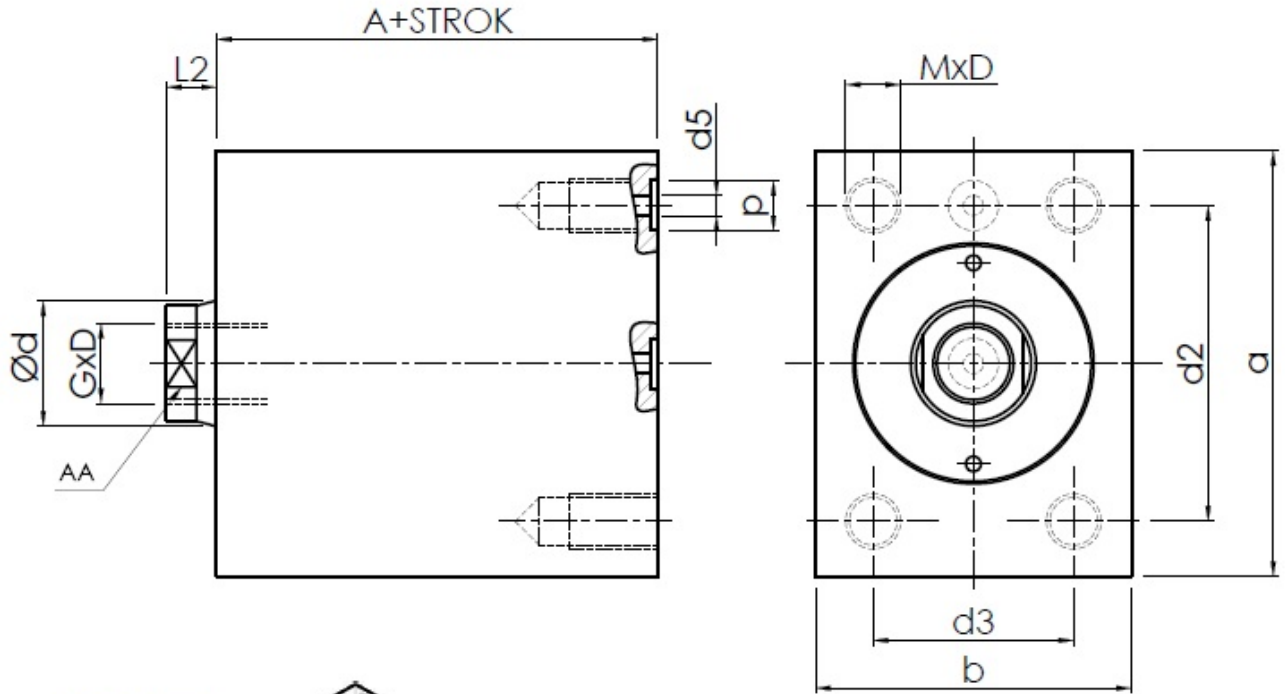

25

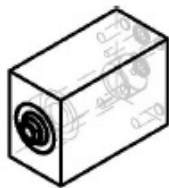

Yastıklama

Cushioning

204

206

208



Ölçüler BSD250 25

Dimensions

Piston Ø – mm / Piston Ø	25	32	40	50	63	80	100
Mil Ød / rod Ø	16	20	25	32	40	50	60
A 204 BS250 ≤100	95	97	105	119	140	156	163
BSU250 >100-200	108	112	125	133	157	174	180
A 206 BS250 ≤100	63	72	78	89	102	114	121
BSU250 >100-200	89	100	113	121	142	160	164
A 208 BS250 ≤100	76	75	81	95	110	127	132
BSU250 >100-200	89	90	101	109	127	145	149
a	65	75	85	100	125	160	200
b	45	55	63	75	95	120	150
d2	50	55	63	76	95	120	158
d3	30	35	40	45	65	80	108
d5	4	4	4	5	6	6	8
L2	7	10	10	10	14	14	15
p	9	9	9	10	10	13	15
AA	13	17	21	26	32	41	---
GxD	M10x15	M12x15	M16x25	M20x30	M27x40	M30x40	M42x60
MxD	M8x16	M10x20	M10x20	M12x24	M16x32	M20x35	M24x50

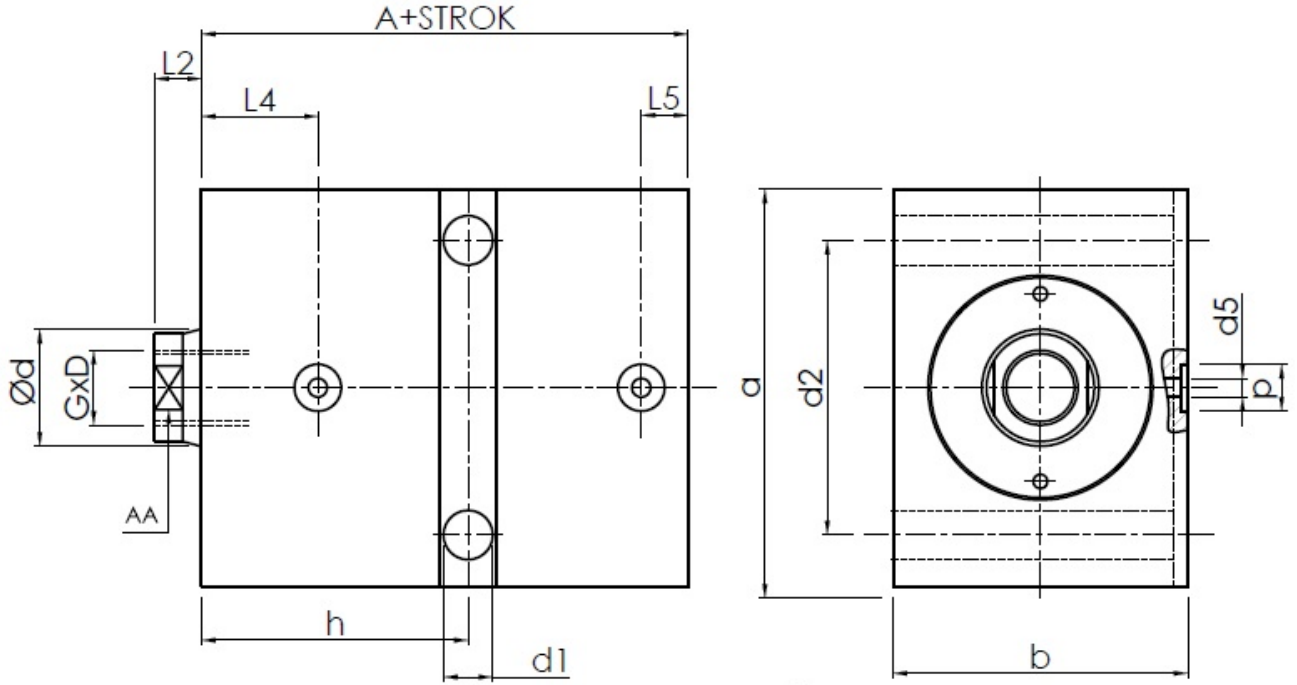

33

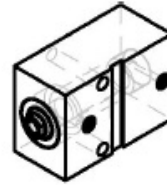
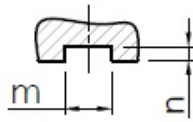

Yastıklama

Cushioning

204

206

208



Ölçüler BSD250 33

Dimensions

Piston Ø – mm / Piston Ø		25	32	40	50	63	80	100
Mil Ød / rod Ø		16	20	25	32	40	50	60
A 204	BS250 ≤100	95	97	105	119	140	156	163
	BSU250 >100-200	108	112	125	133	157	174	180
A 206	BS250 ≤100	63	72	78	89	102	114	121
	BSU250 >100-200	89	100	113	121	142	160	164
A 208	BS250 ≤100	76	75	81	95	110	127	132
	BSU250 >100-200	89	90	101	109	127	145	149
a		65	75	85	100	125	160	200
b		45	55	63	75	95	120	150
d1		8.5	10.5	10.5	13	17	21	25
d2		50	55	63	76	95	120	158
d5		4	4	4	5	6	6	8
h 204 206	BS250 BSU250	33	38	40	44	50	43	45
	BSU250 >100-200	33	38	40	44	50	60	64
h 208	BS250 ≤100	33	38	40	44	50	58	40
	BSU250 >100-200	33	38	40	44	50	60	64
L2		7	10	10	10	14	14	15
L4 204 206	BS250 BSU250	21	26	28	32	35	43	45
L4 208	BS250 BSU250	21	25	27	29,5	32	39	40
L5 204 208	BS250 BSU250	21	26	28	32	35	43	45
L5 206	BS250 ≤100	7,5	10	10	13	16	21	25
	BSU250 >100-200	21	25	27	29,5	32	39	40
m		10	12	12	15	20	24	28
n		2	3	3	5	5	7	7
p		9	9	9	10	10	13	15
AA		13	17	21	26	32	41	---
GxD		M10x15	M12x15	M16x25	M20x30	M27x40	M30x40	M42x60

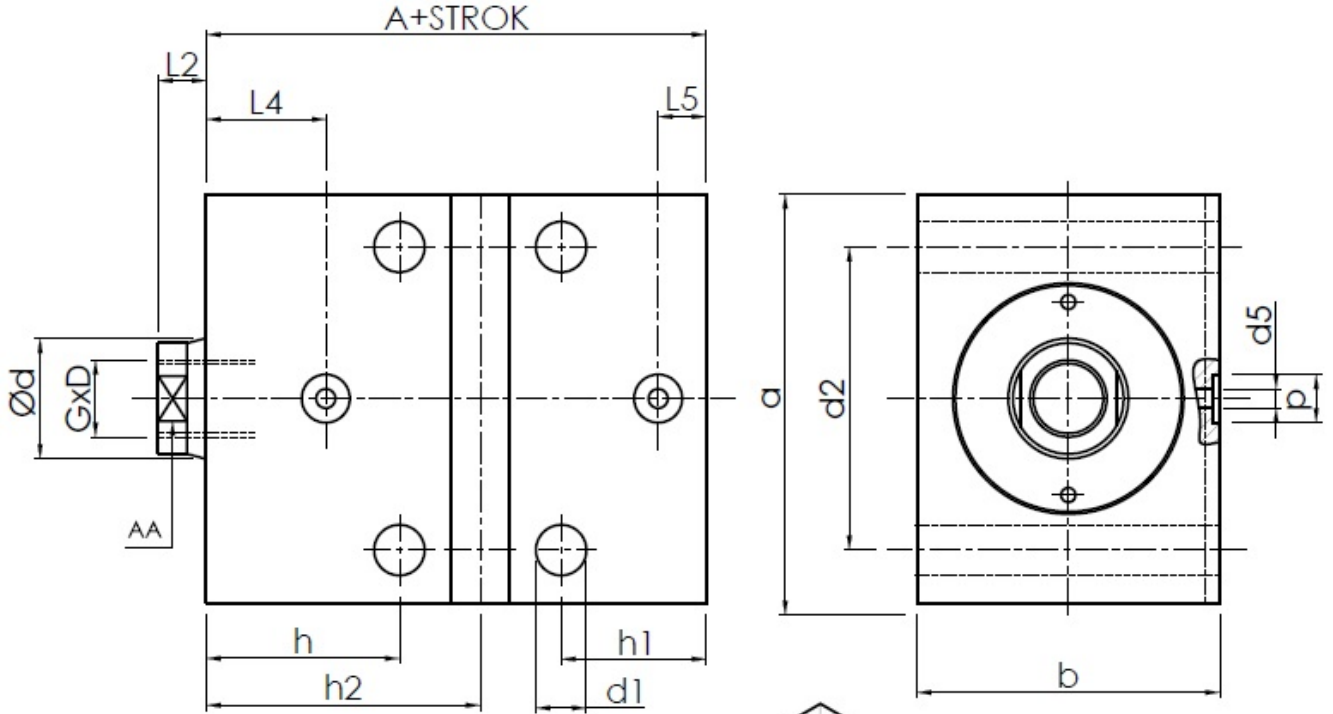

33*

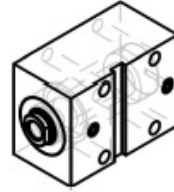
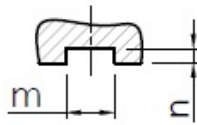

*Ø16-63 strok = 100 mm Ø80-100 strok ≥ 100 mm

Yastıklama

Cushioning

204

206

208



Ölçüler BSD250 33*

Dimensions

Piston Ø – mm / Piston Ø	25	32	40	50	63	80	100
Mil Ød / rod Ø	16	20	25	32	40	50	60
A 204 BS250 ≤100	95	97	105	119	140	156	163
BSU250 >100-200	108	112	125	133	157	174	180
A 206 BS250 ≤100	63	72	78	89	102	114	121
BSU250 >100-200	89	100	113	121	142	160	164
A 208 BS250 ≤100	76	75	81	95	110	127	132
BSU250 >100-200	89	90	101	109	127	145	149
a	65	75	85	100	125	160	200
b	45	55	63	75	95	120	150
d1	8.5	10.5	10.5	13	17	21	25
d2	50	55	63	76	95	120	158
d5	4	4	4	5	6	6	8
h 204 206 BS250 BSU250	33	38	40	44	50	43	45
BSU250 >100-200	33	38	40	44	50	60	64
h 208 BS250 ≤100	33	38	40	44	50	58	40
BSU250 >100-200	33	38	40	44	50	60	64
h1	26	27	27	30	41	47	54
h1 204 208 BS250 BSU250	26	27	27	30	41	60	64
h1 206 BSU250 >100-200	33	38	40	44	50	60	64
h2	Standart üretimde h2=h. Farklı ölçü talep edilebilir. Standart production h2=h. Different size can be requested.						
L2	7	10	10	10	14	14	15
L4 204 206 BS250 BSU250	21	26	28	32	35	43	45
L4 208 BS250 BSU250	21	25	27	29,5	32	39	40
L5 204 208 BS250 BSU250	21	26	28	32	35	43	45
L5 206 BS250 ≤100	7,5	10	10	13	16	21	25
BSU250 >100-200	21	25	27	29,5	32	39	40
m	10	12	12	15	20	24	28
n	2	3	3	5	5	7	7
p	9	9	9	10	10	13	15
AA	13	17	21	26	32	41	---
GxD	M10x15	M12x15	M16x25	M20x30	M27x40	M30x40	M42x60

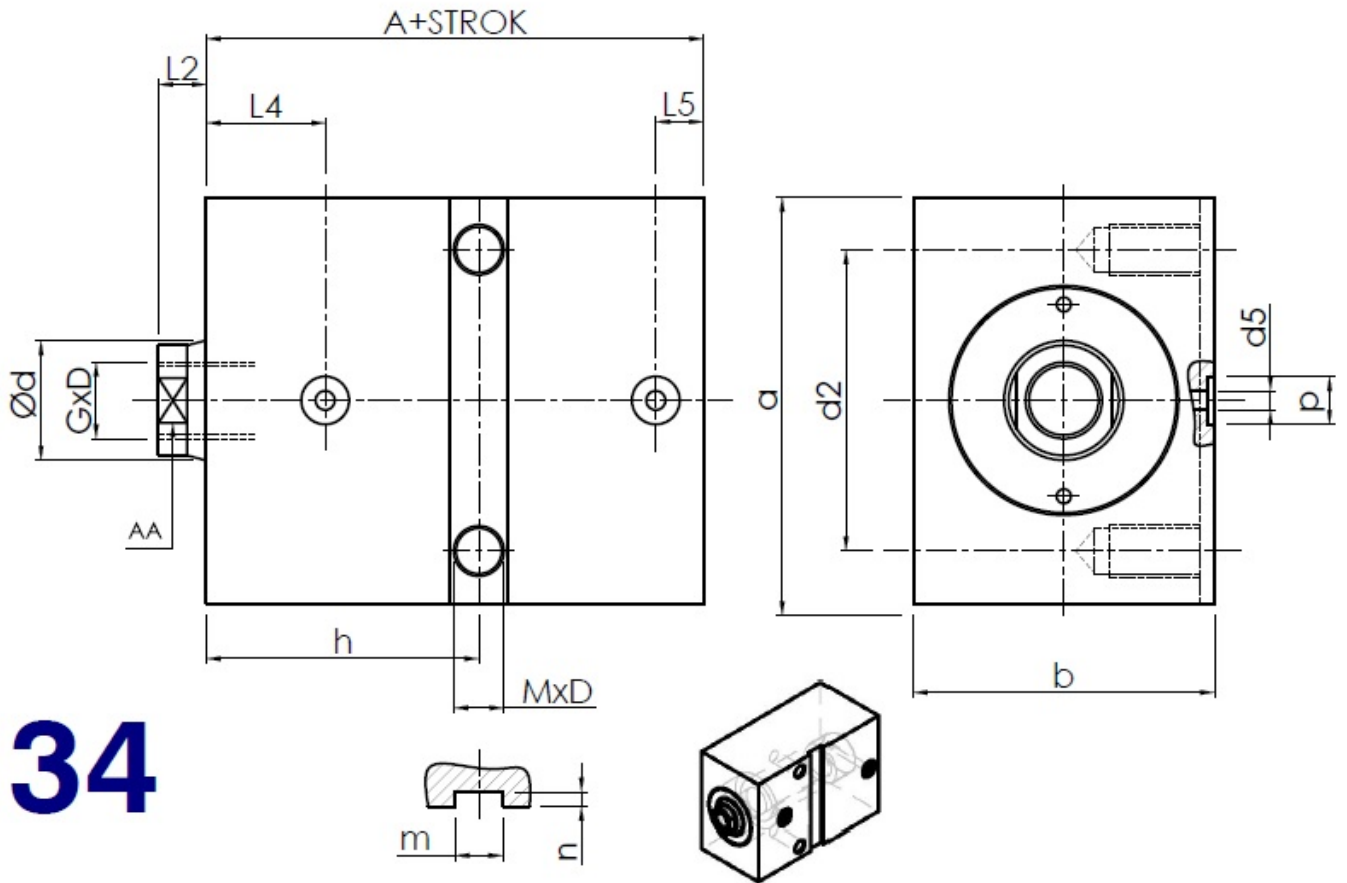

Yastıklama

Cushioning

204

206

208



Ölçüler BSD250 34

Dimensions

Piston Ø – mm / Piston Ø		25	32	40	50	63	80	100
Mil Ød / rod Ø		16	20	25	32	40	50	60
A 204	BS250 ≤100	95	97	105	119	140	156	163
	BSU250 >100-200	108	112	125	133	157	174	180
A 206	BS250 ≤100	63	72	78	89	102	114	121
	BSU250 >100-200	89	100	113	121	142	160	164
A 208	BS250 ≤100	76	75	81	95	110	127	132
	BSU250 >100-200	89	90	101	109	127	145	149
a		65	75	85	100	125	160	200
b		45	55	63	75	95	120	150
d2		50	55	63	76	95	120	158
d5		4	4	4	5	6	6	8
h 204 206	BS250 BSU250	33	38	40	44	50	43	45
	BSU250 >100-200	33	38	40	44	50	60	64
h 208	BS250 ≤100	33	38	40	44	50	58	40
	BSU250 >100-200	33	38	40	44	50	60	64
L2		7	10	10	10	14	14	15
L4 204 206	BS250 BSU250	21	26	28	32	35	43	45
L4 208	BS250 BSU250	21	25	27	29,5	32	39	40
L5 204 208	BS250 BSU250	21	26	28	32	35	43	45
L5 206	BS250 ≤100	7,5	10	10	13	16	21	25
	BSU250 >100-200	21	25	27	29,5	32	39	40
m		10	12	12	15	20	24	28
n		2	3	3	5	5	7	7
p		9	9	9	10	10	13	15
AA		13	17	21	26	32	41	---
GxD		M10x15	M12x15	M16x25	M20x30	M27x40	M30x40	M42x60
MxD		M8x16	M10x20	M10x20	M12x24	M16x32	M20x35	M24x50

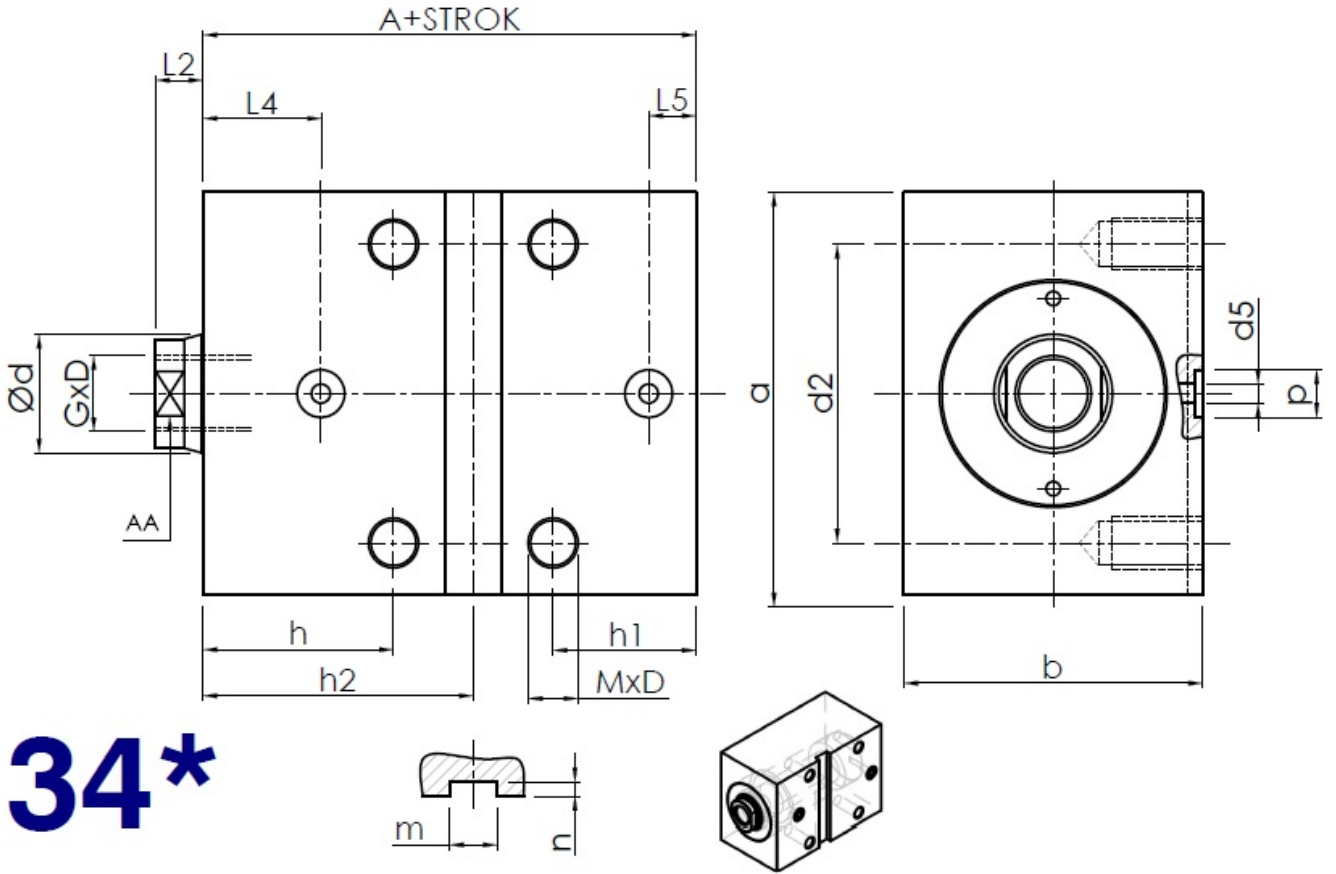

34*

*Ø16-63 strok = 100 mm Ø80-100 strok ≥ 100 mm

Yastıklama

Cushioning

204

206

208



Ölçüler

Dimensions

Piston Ø – mm / Piston Ø		25	32	40	50	63	80	100
Mil Ød / rod Ø		16	20	25	32	40	50	60
A 204	BS250 ≤100	95	97	105	119	140	156	163
	BSU250 >100-200	108	112	125	133	157	174	180
A 206	BS250 ≤100	63	72	78	89	102	114	121
	BSU250 >100-200	89	100	113	121	142	160	164
A 208	BS250 ≤100	76	75	81	95	110	127	132
	BSU250 >100-200	89	90	101	109	127	145	149
a		65	75	85	100	125	160	200
b		45	55	63	75	95	120	150
d2		50	55	63	76	95	120	158
d5		4	4	4	5	6	6	8
h 204 206	BS250 BSU250	33	38	40	44	50	43	45
	BSU250 >100-200	33	38	40	44	50	60	64
h 208	BS250 ≤100	33	38	40	44	50	58	40
	BSU250 >100-200	33	38	40	44	50	60	64
h1	BS250 ≤100	26	27	27	30	41	43	45
h1 204 208	BSU250 >100-200	26	27	27	30	41	60	64
h1 206	BSU250 >100-200	33	38	40	44	50	60	64
h2	Standart üretimde h2=h. Farklı ölçü talep edilebilir. Standart production h2=h. Different size can be requested.							
L2		7	10	10	10	14	14	15
L4 204 206	BS250 BSU250	21	26	28	32	35	43	45
L4 208	BS250 BSU250	21	25	27	29,5	32	39	40
L5 204 208	BS250 BSU250	21	26	28	32	35	43	45
L5 206	BS250 ≤100	7,5	10	10	13	16	21	25
	BSU250 >100-200	21	25	27	29,5	32	39	40
m		10	12	12	15	20	24	28
n		2	3	3	5	5	7	7
p		9	9	9	10	10	13	15
AA		13	17	21	26	32	41	---
GxD		M10x15	M12x15	M16x25	M20x30	M27x40	M30x40	M42x60
MxD		M8x16	M10x20	M10x20	M12x24	M16x32	M20x35	M24x50

Kodlama

Codification

		BSD250	50	/	32	/	25	/	01	/	204	/	Z
• Silindir Tipi	Cylinder Type												
• Piston Çapı Ø mm	Piston Ø mm												
• Mil Çapı Ø mm	Piston-rod Ø mm												
• Strok mm	Stroke mm												
• Gövde Yapısı	Construction form												
• Yastıklama	Cushioning												
• Opsiyon	Option												

Sipariş Örneği

Example of order

BSD250 50 / 32 / 25 / 01 / 204 / Z

BS250 seri Hidrokraft Blok Silindiri Piston çapı Ø50mm Mil çapı Ø32mm Strok 25 mm Gövde yapısı 01 Yastıklama Merkezeleme faturası	Hidrokraft BS250 serie block cylinder piston Ø50mm piston-rod Ø32mm stroke 25 mm construction form 01 cushioned with centering collar
--	---